

# AUTOMATIC VOLTAGE REGULATOR (MODEL : AVR-126)

● **WARNING :**

**To prevent personal injury or equipment damage, only qualified technicians /operators should install, operate or service this device.**

● **CAUTION :**

**Megger and high potential test equipment should not be used.  
Incorrect use of such equipment could damage components contained in the regulator.**

1. APPLICATION : AVR 125 is voltage regulator to control brushless generator output by regulating the current into the generator exciter field.

2. FEATURES :

- 2.1. Available for low resistance exciter filed.
- 2.2. Under frequency protection circuit.  
When the generator frequency drops below the set point, generator output voltage is decreased with the curve proportional to the frequency.
- 2.3. Over excitation  
When the generator excitation field voltage exceeds 85Vdc, AVR output shut down to protect the generator winding coil from burning out.
- 2.4. Starting engine generator set, if the residual voltage remains on the stator winding of generator, AC output voltage is built up rapidly.
- 2.5. Durable under dust, damp and vibration.
- 2.6. Response time, below 25ms(1.5cycles)

3. SPECIFICATIONS

- 3.1. Input : 190~277Vac, 1  $\Phi$ , 50/60Hz, Burden 650VA (terminal 3-4)
- 3.2. Output :

MODEL	VOLTAGE	CURRENT	REMARKS
AVR - 125	125Vdc	15A	continuous

Maximum current (for 1min.) - 20A

- 3.3. Sensing : 1  $\Phi$ , 190 ~ 240Vac (220V sensing – terminal 4-3)  
1  $\Phi$ , 380 ~ 400Vac (380V sensing – terminal 4-E1)
- 3.4. Exciter field resistance : 2ohms to 100ohms
- 3.5. External voltage adjust rheostat : 1 k $\Omega$ , 2W (**out of supply scope**)
- 3.6. Voltage adjust range  
Coarse adjusting (by internal rheostat)  $\pm 12.5\%$   
Fine adjusting (by external rheostat)  $\pm 5\%$
- 3.7. voltage regulating accuracy  $\pm 1.0\%$
- 3.8. Voltage build up condition internally and automatically raised by the residual voltage from the Generator stator winding (minimum 3Vac)

- 3.9. Over excitation shut down : when exciter field voltage exceeds the following, AVR output is removed. Otherwise, exciter field voltage keeps on over  $85 \pm 5\text{Vdc}$  for 10sec, or instantaneously it exceeds 100Vdc.  
After shutdown, to reset the regulator, generator set should be stopped or the power input to the AVR Should be interrupted for more than 20seconds.
- 3.10. Operating temperature :  $-20^{\circ}\text{C}(-8^{\circ}\text{F})$  to  $50^{\circ}\text{C}(140^{\circ}\text{F})$
- 3.11. Storage temperature :  $-40(-40^{\circ}\text{F})$  to  $85^{\circ}\text{C}(185^{\circ}\text{F})$

#### 4. STRUCTURE

- 4.1. Size : W175 x H185 x D75(mm)
- 4.2. Mounting size : W165 x H115(mm) x  $6\Phi$  - 4Holes
- 4.3. Color : bottom and cover - ivory
- 4.4. Frequency selection : changeover switch
- 4.5. Weight : about 2.6kg

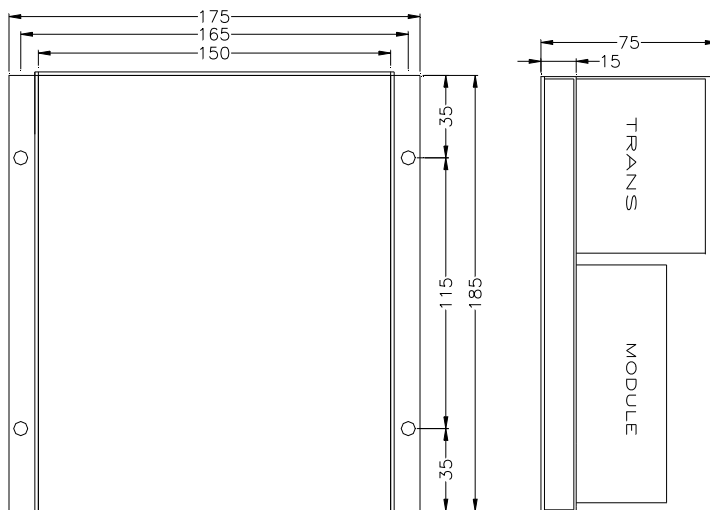

#### 5. INSTRUCTION AND CONNECTION

##### ●NOTE

**Prior to mounting the regulator, generator manufacture should check whether regulator output current meet the capacitor of exciter.**

- 5.1. Mounting  
See above diagrams for mounting AVR in the generator conduct box or the generator control and Switch gear.  
It is recommend that AVR be mounted with the front panel to be showed all marks straight and easily in the vertical plane.
- 5.2. Connection  
Refer to the following drawings for the correct connection.

GEN 220V connection

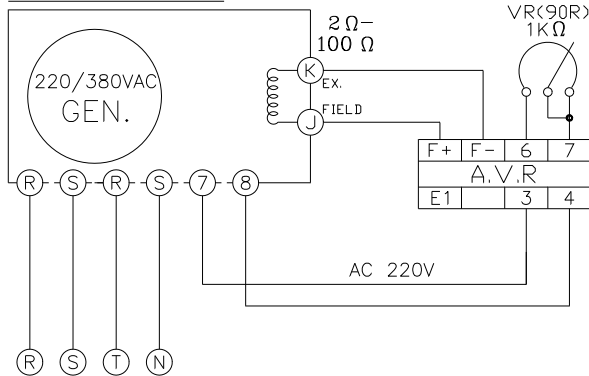

GEN 380V connection

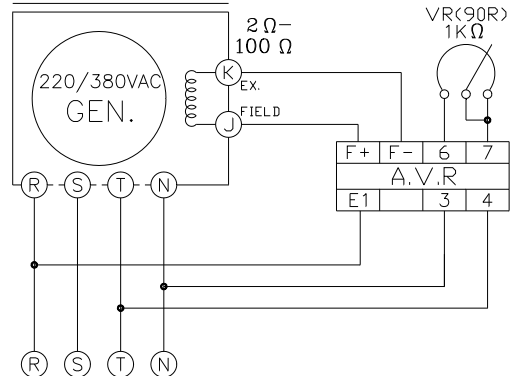

- ▶ Remote voltage adjust  
Remove the jumper from the terminal 6 and 7, and connect the remote voltage adjust potentiometer (rheostat) to the terminals 6 and 7 as specified.
- ▶ Sensing voltage  
Generator voltage sensing is single-phase 220Vac or 380Vac.  
It can be selected in accordance with generator output voltage (or rated voltage) as follows,  
\*380V sensing (terminal 4-E1) ; As generator output voltage is 380, 400 and 440V ,415V  
\*220V sensing (terminal 4-3) ; As generator output voltage 208, 220 and 230V
- ▶ Power input  
The power input terminal of the regulator are marked power input AC 220V
- ▶ Power output  
The two power output terminals of the regulator are marked F+, F-  
These two lines are connected to the F+, F- (or J, K) of exciter field respectively.

## 6. ADJUSTING

- 6.1. Start prime mover and bring up to rated speed.
- 6.2. Voltage would be automatically built up.  
If not, confirm until voltage build up through the DC power connection to directly the J,K terminal of generator ,with BATT. (+) and BATT, (-) under disconnecting lines F+ and F- from the regulator.
- 6.3. If a minimum residual of 3 VAC is not present, perform field flashing by using 12Vdc battery and Contactor as below drawing. Please refer to 7.FLASH EXCITING. for details.
- 6.4. Adjust volt potentiometer until voltage reaches nominal value.
  - ▶ Coarse voltage adjustment  
: internal rheostat, single turn
  - ▶ Fine voltage adjustment  
: external remote rheostat, single turn, set point should be mid position to notice easily
- 6.5. Adjust for stab potentiometer if voltage is unstable.  
(Adjusting stability changes the response time of regulator,

- ▶ turning CW increase the level for damping generator transient output voltage.
- ▶ turning CCW decrease damping level to cause under damping

#### 6.6. Choice frequency switch depending on generator frequency (SW1)

This option protects generator and AVR by decreasing generator output voltage if it reduces generator frequency. (under frequency protection)

- Frequency 50Hz system (refer to below 50Hz system)
- Frequency 60Hz system (refer to below 60Hz system)

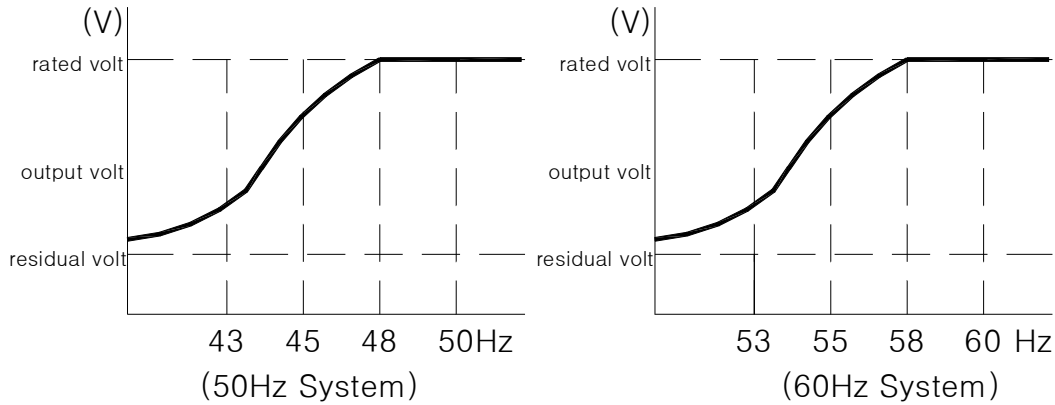

### 7. FLASH EXCITING

#### 7.1. MANUAL FIELD FLASH ESCITING

When generator does not build up to the rated value or has no output, manual field flash exciting could be executed as the following order. Please refer to the below drawing.

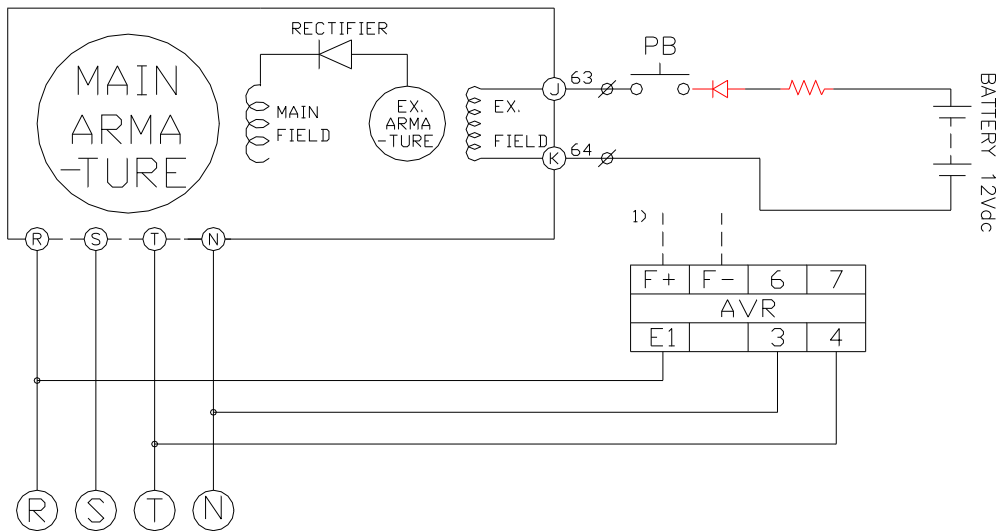

- 1) Remove two output lines connected to the terminals J, K of generator.
- 2) Prepare a 12Vdc battery and a push button, and connect them as the drawing.
- 3) Start engine
- 4) When the revolution is reached rating, push the button for short time (about 1~2sec)
- 5) Check the output voltage.

- 6) Stop the engine and remove battery and push button.
- 7) Reconnect all wires.
- 8) Start engine and check the output voltage.

● **NOTE**

To take flash exciting without engine running, keep the button on a pushed condition to close the flash exciting circuit for 30sec.

7.2. AUTOMATIC FILED FLASH EXCITING

Whenever start generator set, to avoid no output voltage. It is recommended to take automatic field flash exciting by using the generator control sequence as below drawing.

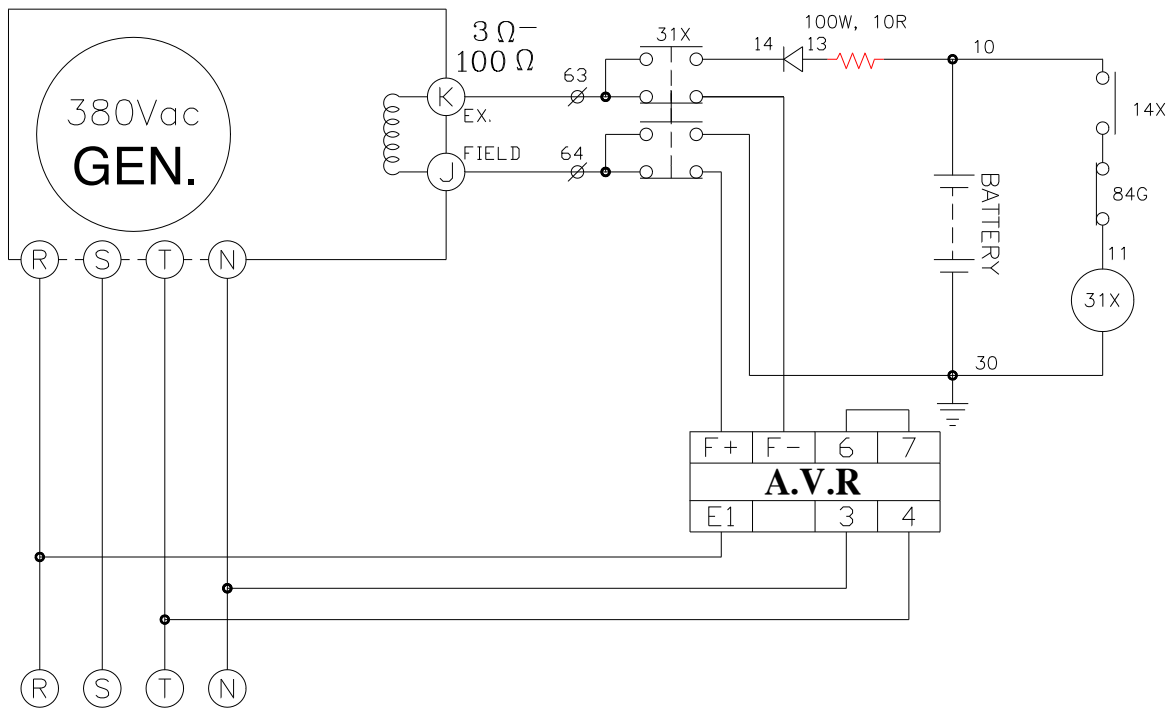

8. PARALLE OPERATION

AVR 125 are not designed for parallel operation ,but connecting a external variable resistance with a toggle switch as below drawing, in series with one line of two input sensing lines to the regulator, the the regulator can run in droop performance for inductive load.

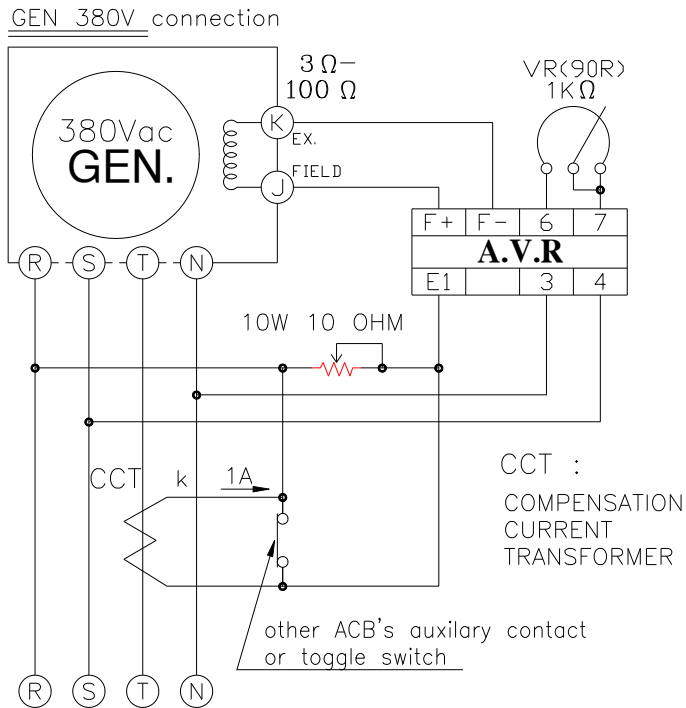

## 9. TROUBLE SHOOTING

SYMPTOM	CAUSE	ACTION
Residual Voltage- No Output	Residual voltage at regulator power input wires 3 & 4 below 3Vac.	Check wiring diagram for proper Connections. Flash generator field. Refer to 7.FLASH EXCITING section in generator manual.
	Field leads F+, F- not connected.	Connect field lead F+, F-.
	Power input leads not connected.	Connect power input leads 3, 4.
	Blown or missing fuse.	Replace fuse.
	Defective regulator.	Replace regulator.
	Defective generator.	Consult generator manual.

Output Voltage Low	<p>Incorrect connections.</p> <p>Voltage adjust turned down.</p> <p>Remote voltage adjust is turned down.</p> <p>Defective regulator.</p>	<p>Check wiring diagram for proper connections. Incorrect sensing voltage connection can cause output voltage low-no adjustment.</p> <p>Rotate voltage adjust CW until desired voltage is reached.</p> <p>Rotate remote voltage adjust CW until desired voltage is reached.</p> <p>Replace regulator.</p>
Output Voltage High	<p>Voltage adjust turned too high.</p> <p>Remote voltage adjust is turned too high</p>	<p>Rotate voltage adjust CCW until desired voltage is reached.</p> <p>Rotate remote voltage adjust CCW until desired voltage is reached.</p>
Output Voltage High-No Adjustment	Defective regulator.	Replace regulator.
Rating Output Voltage at no load and Voltage Down at load condition	Generator defective	Check the generator exciter and rotating diode
Remote voltage Adjust Operates backwards	Voltage adjust wire backwards.	Reverse the wiring of the connection on the remote voltage adjust.
Generator Output Voltage Hunting	Defective regulator	Rotate the stability adjust in a CW direction until hunting stops
Poor Regulation	Defective regulator.	Replace regulator.